

(19) World Intellectual Property Organization
International Bureau



(43) International Publication Date
14 February 2002 (14.02.2002)

PCT

(10) International Publication Number
WO 02/12923 A1

(51) International Patent Classification⁷: G01V 5/00

(21) International Application Number: PCT/GB01/03486

(22) International Filing Date: 2 August 2001 (02.08.2001)

(25) Filing Language: English

(26) Publication Language: English

(30) Priority Data:
0019451.4 9 August 2000 (09.08.2000) GB

(71) Applicant (for all designated States except US): THE SECRETARY OF STATE OF DEFENCE [GB/GB]; DSTL, Salisbury, Wiltshire SP4 0JQ (GB).

(72) Inventors; and

(75) Inventors/Applicants (for US only): JUPP, Ian [GB/GB]; Defence Evaluation Research Agency, DERA Malvern, St. Andrew's Road, Malvern, Worcestershire WR14 3PS (GB). CATER, Anthony [GB/GB]; DRPS, INM, Crescent Road, Alverstoke, Gosport, Hants PO12 2DL (GB). DERMODY, Geraint [GB/GB]; DSTL, Port Down,

Salisbury, Wilts SP4 0JQ (GB). PLEASANTS, Ian [GB/GB]; DSTL, Fort Halstead, Sevenoaks, Kent TN14 7BP (GB). BURROWS, David [GB/GB]; DSTL, Fort Halstead, Sevenoaks, Kent TN14 7BP (GB).

(74) Agents: REGAN-ADDIS, Heather et al.; Harrison Goddard Foote, Orlando House, 11c Compstall Road, Marple Bridge, Stockport SK6 5HH (GB).

(81) Designated States (national): AE, AG, AL, AM, AT, AU, AZ, BA, BB, BG, BR, BY, BZ, CA, CH, CN, CO, CR, CU, CZ, DE, DK, DM, DZ, EC, EE, ES, FI, GB, GD, GE, GH, GM, HR, HU, ID, IL, IN, IS, JP, KE, KG, KP, KR, KZ, LC, LK, LR, LS, LT, LU, LV, MA, MD, MG, MK, MN, MW, MX, MZ, NO, NZ, PL, PT, RO, RU, SD, SE, SG, SI, SK, SL, TJ, TM, TR, TT, TZ, UA, UG, US, UZ, VN, YU, ZA, ZW.

(84) Designated States (regional): ARIPO patent (GH, GM, KE, LS, MW, MZ, SD, SL, SZ, TZ, UG, ZW), Eurasian patent (AM, AZ, BY, KG, KZ, MD, RU, TJ, TM), European patent (AT, BE, CH, CY, DE, DK, ES, FI, FR, GB, GR, IE, IT, LU, MC, NL, PT, SE, TR), OAPI patent (BF, BJ, CF, CG, CI, CM, GA, GN, GQ, GW, ML, MR, NE, SN, TD, TG).

[Continued on next page]

(54) Title: APPARATUS FOR IMAGING OBJECTS ON THE REMOTE SIDE OF A BARRIER USING RADIATION

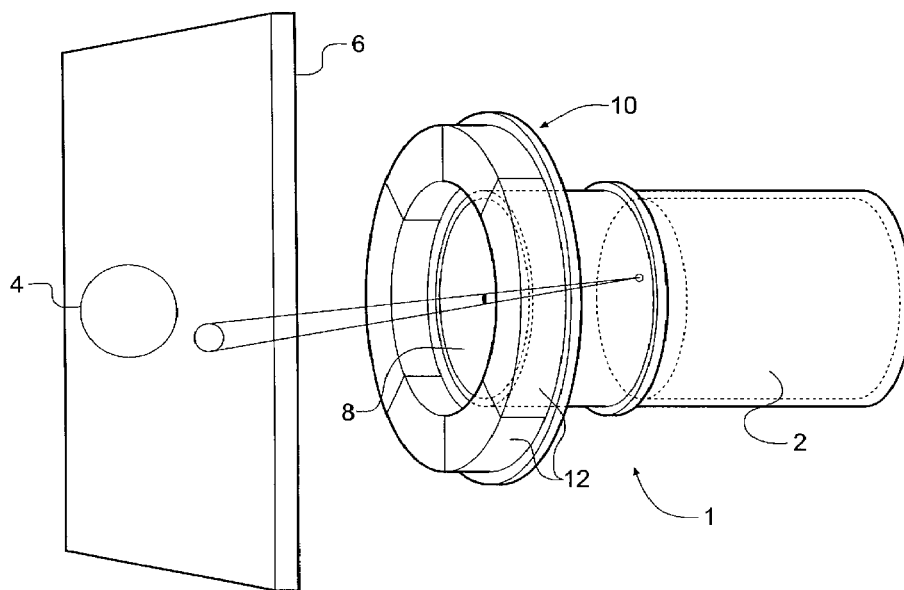

(57) Abstract: Apparatus (1) for imaging an object (4) on the remote side of a barrier (6). The apparatus has source means (2) for scanning the object (4) through the barrier (6) with radiation and mask means (8) having at a least one radiation transparent area wherein the radiation from the source is masked thereby to project on to the object (4) at least one scanning beam of radiation. The apparatus (1) also has detector means (10) for detecting radiation reflected from any scanned point on the object (4) and image generation means for generating an image of the object (4) from the detected radiation.



WO 02/12923 A1



Published:

- with international search report
- before the expiration of the time limit for amending the claims and to be republished in the event of receipt of amendments

For two-letter codes and other abbreviations, refer to the "Guidance Notes on Codes and Abbreviations" appearing at the beginning of each regular issue of the PCT Gazette.

APPARATUS FOR IMAGING OBJECTS ON THE REMOTE SIDE OF A BARRIER USING RADIATION

The invention relates to imaging apparatus and particularly to apparatus for imaging objects to the remote side of a barrier.

5

It is well known to carry out security screening using x-ray apparatus. For example, at airports, passenger hand luggage is screened for explosives articles. Such screening tends to be carried out using shadow techniques. By means of a movable x-ray beam from a continuously driven x-ray source, the luggage may be line scanned from one side. To the other side is a large array of x-ray detectors. Any x-ray impermeable objects within the luggage will cast a shadow on to the arrays. The shadows are converted to screen images which are scrutinised by an operator.

10

The reverse geometry x-ray (RGX) tube may, for instance, produce a scanning x-ray emission region across a 250mm diameter tungsten anode. Typically the emission region will be up to 20µm in diameter and up to 1024 x 1024 scan positions may be used to define the line scanned region.

15

X-rays impinging upon an object may undergo Compton scattering. This is the result of interaction between the x-ray photons and the electrons of the object. The x-rays may be scattered at various angles and flux intensities, according to the composition of the object. Some will be back scattered to the side of the object at which the source is located. In our co-pending UK application no (applicant's agents ref: P21107GB) we disclose a camera for imaging an object on the remote side of a barrier using back-scattered x-rays.

20
25

If back scattered x-rays are to be used for object imaging, but without a camera, what is required is high resolution imaging apparatus for producing high statistical quality images in short exposure times. Also, security personnel have a requirement for a non-invasive system of determining the contents of an item without having to relocate it. For example, unclaimed luggage left on the platform of an underground

30

train station requires explosion threat assessment, but moving the luggage in order to determine its contents is of itself risky. Hence there is a need to be able to determine the contents in situ.

- 5 Known back-scatter x-ray screening apparatus is not easily portable, not least because it tends to use a mechanically scanned x-ray beam, necessitating equipment of a size and weight which does not lend itself to portability.

10 Coded aperture x-ray cameras are well known. These may conventionally have a suitable x-ray detector and a mask situated between the detector and an object under assessment. The mask has x-ray transparent areas arranged in a pre-determined, coded, pattern. X-ray flux from any point source on the object is masked so as to project on to the detector a pattern of flux corresponding to the pattern of the mask. The position of the projected flux pattern is determined by the originating direction
15 of the flux. An image of the object may be reconstructed by decoding the accumulated flux patterns.

The coded aperture camera has advantages over its forerunner, the single pinhole camera. To maintain high resolution, a single pinhole needs to have as small a
20 diameter as possible. To ensure sufficient sensitivity, the pinhole needs to be as large as possible. Thus, the choice of aperture diameter in a single pinhole camera involves a degree of compromise. However, the coded aperture camera, because it in effect has a pattern of multiple pinholes, achieves both high resolution and sufficient sensitivity.

25

Coded aperture imaging is used in astronomy.

The invention provides apparatus for imaging an object on the remote side of a barrier comprising source means for scanning the object through the barrier with
30 radiation, mask means having at least one radiation transparent area wherein the radiation from the source is masked thereby to project on to the object at least one

scanning beam of radiation, detector means for detecting radiation reflected from any scanned point on the object, image generation means for generating an image of the object from the detected radiation.

- 5 The scanning is preferably conducted with sufficient resolution to allow a high frequency of sampling of the object. The scanning may be conducted through a two dimensional array of 1024 x 1024 positions.

10 Preferably, the mask means has a plurality of radiation transparent areas arranged in a predetermined pattern thereby to project on to the object a plurality of scanning beams of radiation of a predetermined pattern.

The use of a mask having a plurality of radiation transparent areas has the advantage over a single radiation transparent area or pinhole in that it allows maximum flux to reach the object, and thereby reduces the time of exposure required to obtain a statistically significant result, whilst still providing an imaging capability with the resolution of a single pinhole.

20 The apparatus may be portable, that is to say, it may be of a size and weight which lends itself portability. Individual elements of the apparatus may be portable or the apparatus may be portable as a whole. Portability enables the apparatus to be taken to the location of an object requiring assessment which, as aforementioned, is advantageous in the case of objects requiring elimination as security threats.

- 25 The radiation may be back-scattered from the object.

30 The source means may scan the object with x-ray radiation, that is, radiation in the electromagnetic spectrum of wavelengths less than about 1Å. The source means may comprise an x-ray raster scan tube or an RGX tube, which has the advantage that it has an electrostatically rather than mechanically scanned x-ray beam, that is less cumbersome.

The detector means may be generally annular and positioned around the source means, and, for the detection of back-scattered x-rays, may comprise a segmented array of a plurality of scintillation crystal elements, typically eight NaI (TI) crystal
5 elements, read out by photomultiplier tubes. Such a detector may provide excellent stopping power at the required x-ray photon energies, typically up to 100KeV, have a good low energy threshold and may provide sufficient energy resolution to allow the use of energy windowing, that is, detection limited to photons in a selected energy range, which can optimise image quality. In addition, such a detector may provide a
10 large detection area thereby maximising the flux collection process.

If a mask with a plurality of radiation transparent areas is used, the mask pattern is preferably selected, according to a mathematical function, so as to code the scanning beams projected on to the object in a manner which will result in reflected radiation
15 that can be subsequently decoded.

The image generation means may comprise a system driven by software to decode, by mathematical analysis, the detected radiation, thereby to reconstruct an image of the object. The mathematical analysis may comprise filtered deconvolution, matrix
20 inversion, maximum likelihood/maximum entropy reconstruction or cross-correlation.

The invention will now be described by way of example, with reference to the drawings in which:
25

Figure 1 is a schematic diagram of apparatus according to the invention; and

Figure 2 is a schematic diagram of a typical coded mask pattern.

30 With reference to figure 1, an object 4 under assessment is situated to one side of a barrier 6. The object 4 is represented schematically in the figure as a three

dimensional body, but could be a gun, a knife, an explosives detonator. The barrier 6 could be the skin of a brief case, suit case etc.

Portable imaging apparatus, indicated generally at 1, is located to the other side of the barrier 6, typically several metres away. The apparatus 1 comprises a source 2, a mask 8 and a detector 10.

The source 2 is a scanning, reverse geometry x-ray (RGX) tube, of the type available in the USA from the company Digiray, nominally 350 mm in diameter and 950 mm in length, which together with its housing and supporting structure (not shown) weighs approximately 80 Kg. The tube produces x-ray radiation, typically of 300 KeV, that can be electrostatically, that is, using electromagnets, scanned through a two dimensional array of positions, up to a limit, in this case, of 1024 x 1024.

In a first embodiment, the mask 8 is a single pinhole mask having one x-ray transparent area 2mm in diameter. The mask 8 is situated between the source 2 and the barrier 6. The flux from the source 2 is interrupted by the mask 8 such that a scanning pencil beam of x-rays is projected through the barrier 6 and the object 4 is illuminated with a single spot (not shown). The spot is scanned through the 1024 x 1024 positions.

The detector 10 is an annular, large area detector mounted around the RGX tube, and comprises a ring-shaped array of eight NaI (Tl) scintillation crystal elements (not shown) whose outputs are monitored by photomultiplier tubes (not shown). The array nominally has an internal diameter of 380 mm and an external diameter of 650 mm. Each element, nominally 250 x 110 x 320 mm, weighs approximately 5 Kg.

X-ray photons back scattered from any point on the object 4 which is illuminated by the source 2, and which penetrate through the barrier 6, are detected at the detector 10. The detected intensity is recorded in the image at the corresponding RGX scan position.

- In a second embodiment of the invention, the single pinhole mask 8 is replaced by a coded aperture mask, that is to say, a hexagonal mask, approximately 300 mm across, having x-ray transparent areas in a pre-determined pattern. The pattern is chosen according to an autocorrelation function of an appropriate form, that is, a delta function. In effect the mask can be considered as an array of, typically 1000 elements, and selected elements, typically 500, are x-ray transparent. Figure 2 shows typical coded mask patterning.
- 10 With the coded aperture mask interrupting the flux, several beams, in a pattern corresponding to the pattern of the radiation transparent areas, result in the object 4 being illuminated with a pattern of spots. As previously, the photons back scattered are detected as the object is scanned. The detections made by the detector 10 are in encoded form and must be decoded in order to produce a useable image. Image generation is performed using a PC (not shown) which mathematically decodes the output of the detector 10 using its knowledge of the mask pattern, and reconstructs the image.

Claims

1. Apparatus for imaging an object on the remote side of a barrier comprising source means for scanning the object through the barrier with radiation, mask means having at least one radiation transparent area wherein the radiation from the source is masked thereby to project on to the object at least one scanning beam of radiation, detector means for detecting radiation reflected from any scanned point on the object, image generation means for generating an image of the object from the detected radiation.
2. Apparatus according to claim 1 wherein the source means is scanned through a two-dimensional array of 1024 x 1024 positions
3. Apparatus according to claim 1 or claim 2 wherein the mask means has a plurality of radiation transparent areas arranged in a predetermined pattern thereby to project on to the object a plurality of scanning beams of radiation of a predetermined pattern.
4. Apparatus according to any of claims 1 to 3 which is portable.
5. Apparatus according to any of claims 1 to 4 wherein the radiation is back-scattered from the object.
6. Apparatus according to any of claims 1 to 5 wherein the source means scans the object with x-ray radiation.
7. Apparatus according to claim 6 wherein the source means comprises an x-ray raster scan tube or an RGX tube.
8. Apparatus according to any preceding claim wherein the detector means is generally annular and positioned around the source means.

9. Apparatus according to claim 6 wherein the detector means comprises a segmented array of a plurality of scintillation crystals read out by a plurality of photomultiplier tubes.
- 5
10. Apparatus according to claim 3 wherein the mask pattern is selected, according to a mathematical function, thereby to code the scanning beams projected on to the object in a manner which will result in reflected radiation that can be subsequently decoded.
- 10
11. Apparatus substantially as herein described with reference to figures 1 and 2 of the drawings.

1/2

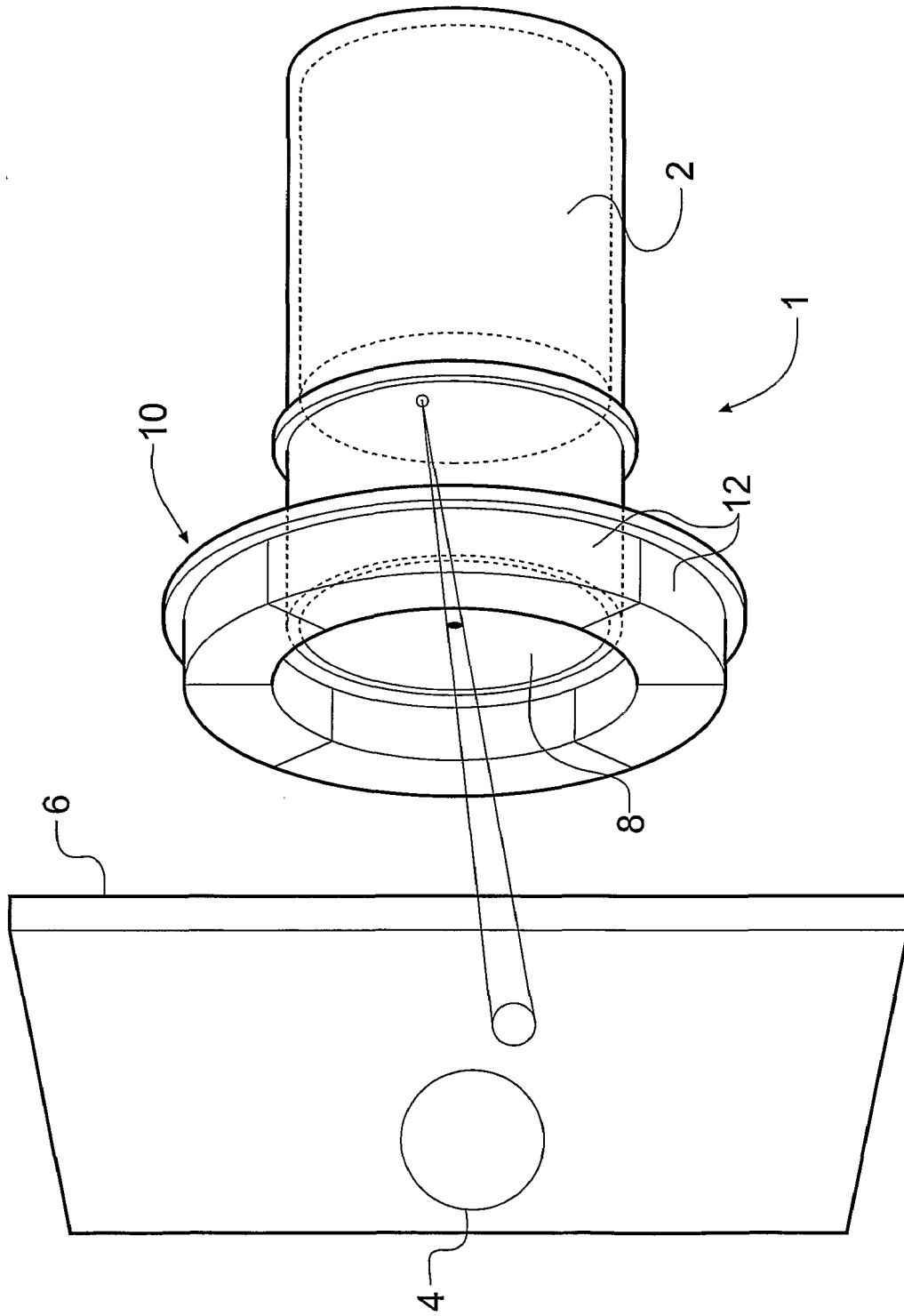

Fig. 1

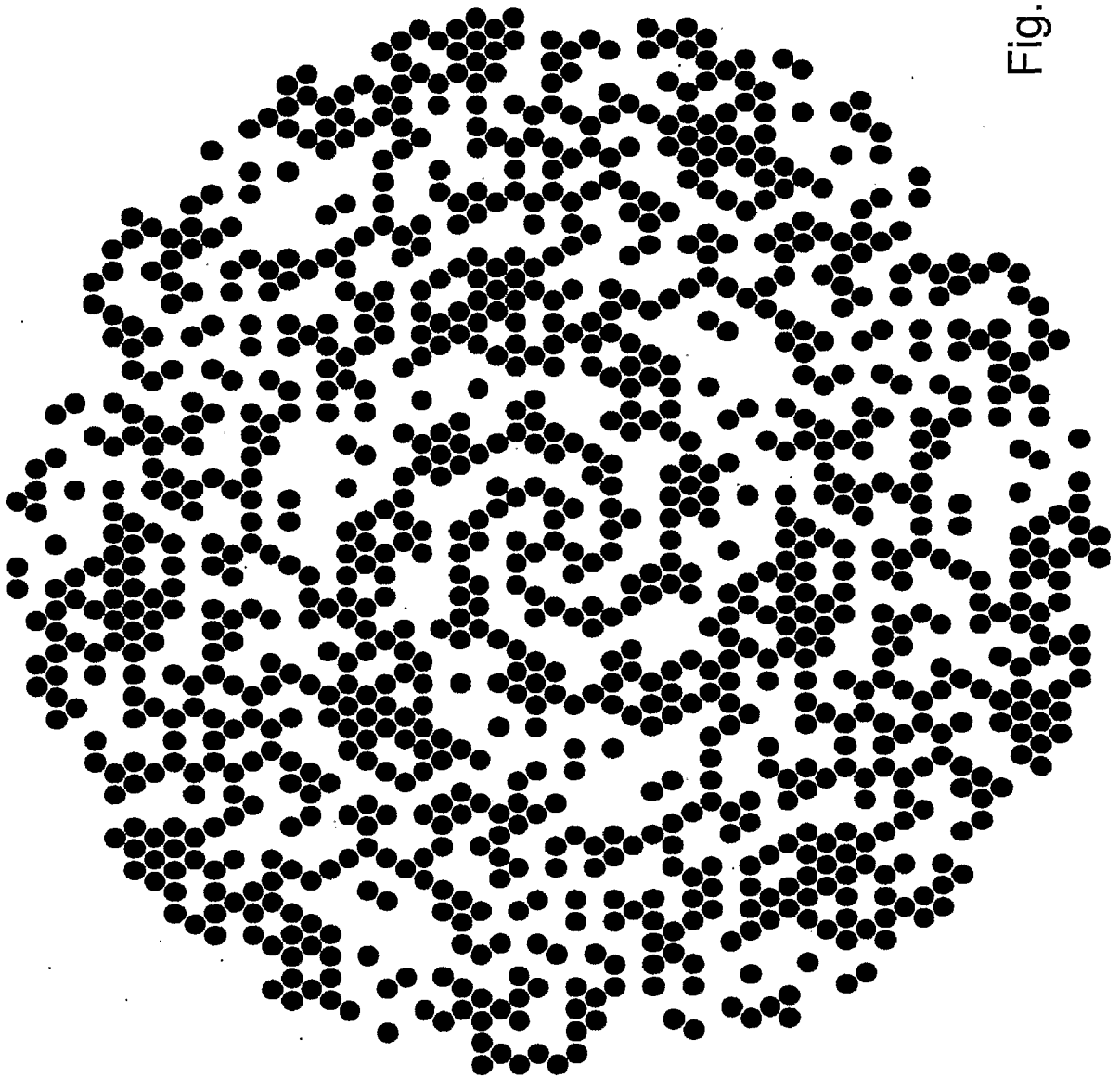

Fig. 2

INTERNATIONAL SEARCH REPORT

International Application No

PCT/GB 01/03486

A. CLASSIFICATION OF SUBJECT MATTER
IPC 7 G01V5/00

According to International Patent Classification (IPC) or to both national classification and IPC

B. FIELDS SEARCHED

Minimum documentation searched (classification system followed by classification symbols)

IPC 7 G01V

Documentation searched other than minimum documentation to the extent that such documents are included in the fields searched

Electronic data base consulted during the international search (name of data base and, where practical, search terms used)

EPO-Internal, WPI Data, PAJ

C. DOCUMENTS CONSIDERED TO BE RELEVANT

Category °	Citation of document, with indication, where appropriate, of the relevant passages	Relevant to claim No.
X	US 5 763 886 A (SCHULTE ROBERT L) 9 June 1998 (1998-06-09) abstract column 2, line 61 - line 62 column 4, line 37 - line 39; figure 6 ---	1, 4-6, 8
A	US 5 940 468 A (HUANG SUZHOU ET AL) 17 August 1999 (1999-08-17) column 3, line 18 - column 4, line 10; figure 1 ---	3, 10
A	US 5 568 532 A (MAJEWSKI STANISLAW ET AL) 22 October 1996 (1996-10-22) abstract column 2, line 23 - line 27 ---	2, 6, 7
	-/--	

Further documents are listed in the continuation of box C.

Patent family members are listed in annex.

° Special categories of cited documents:

A document defining the general state of the art which is not considered to be of particular relevance

E earlier document but published on or after the international filing date

L document which may throw doubts on priority claim(s) or which is cited to establish the publication date of another citation or other special reason (as specified)

O document referring to an oral disclosure, use, exhibition or other means

P document published prior to the international filing date but later than the priority date claimed

T later document published after the international filing date or priority date and not in conflict with the application but cited to understand the principle or theory underlying the invention

X document of particular relevance; the claimed invention cannot be considered novel or cannot be considered to involve an inventive step when the document is taken alone

Y document of particular relevance; the claimed invention cannot be considered to involve an inventive step when the document is combined with one or more other such documents, such combination being obvious to a person skilled in the art.

& document member of the same patent family

Date of the actual completion of the international search

13 December 2001

Date of mailing of the international search report

21/12/2001

Name and mailing address of the ISA

European Patent Office, P.B. 5818 Patentlaan 2
NL - 2280 HV Rijswijk
Tel. (+31-70) 340-2040, Tx. 31 651 epo nl,
Fax: (+31-70) 340-3016

Authorized officer

Anderson, A

INTERNATIONAL SEARCH REPORT

International Application No
GB 01/03486

C.(Continuation) DOCUMENTS CONSIDERED TO BE RELEVANT

Category °	Citation of document, with indication, where appropriate, of the relevant passages	Relevant to claim No.
A	US 4 974 247 A (FRIDDELL KENNETH D) 27 November 1990 (1990-11-27) abstract column 7, line 15 - line 33; figure 1 -----	9

INTERNATIONAL SEARCH REPORT

Information on patent family members

International Application No PCT/GB 01/03486

Patent document cited in search report	A	Publication date	Patent family member(s)	Publication date
US 5763886	A	09-06-1998	AU 716334 B2 AU 3202297 A CA 2250279 A1 EP 0917650 A1 JP 2000515629 T NO 985218 A WO 9805946 A1	24-02-2000 25-02-1998 12-02-1998 26-05-1999 21-11-2000 30-03-1999 12-02-1998
US 5940468	A	17-08-1999	WO 9820366 A1	14-05-1998
US 5568532	A	22-10-1996	NONE	
US 4974247	A	27-11-1990	US 5033073 A	16-07-1991